

XLTI

Caratteristiche Tecniche

Albero maschio – Solid shaft

Technical Characteristics

Pump Pompa	Pressure Pressione		Volume Portata				RPM giri/min		Power Potenza			
			l/min		GPM				HP		kW	
	bar	PSI	50 Hz	60 Hz	50 Hz	60 Hz	50 Hz	60 Hz	50 Hz	60 Hz	50 Hz	60 Hz
XLT3020IS	200	2900	30	36	7.9	9.5	1000	1200	15.6	18.7	11.5	13.8
XLT3816IS	160	2320	38	46	10.0	12.0	1000	1200	15.9	19.0	11.7	14.0
XLT1530I	300	4350	15	18	4.0	4.7	1450	1740	11.5	13.8	8.5	10.2
XLT1830I	300	4350	18	22	4.8	5.8	1450	1740	13.7	16.4	10.1	12.1
XLT2230I	300	4350	22	26	5.8	7.0	1450	1740	16.6	19.9	12.2	14.6
XLT2530I	300	4350	25	30	6.6	7.9	1450	1740	19.2	23.0	14.1	16.2
XLT2730I	300	4350	27	32	7.1	8.5	1450	1740	20.5	24.6	15.1	18.1
XLT3025I	250	3625	30	36	7.9	9.5	1450	1740	19.3	23.2	14.2	17.0
XLT3325I	250	3625	33	40	8.7	10.4	1450	1740	21.4	25.7	15.7	18.8
XLT3517I	170	2465	35	42	9.2	11.0	1450	1740	15.2	18.2	11.2	13.4
XLT4017I	170	2465	40	48	10.6	12.7	1450	1740	17.0	20.4	12.5	15.0
XLT4317I	170	2465	43	52	11.4	13.7	1450	1740	19.1	22.9	14.1	16.9
XLT5015I	150	2175	50	60	13.2	15.8	1450	1740	18.8	22.6	13.8	16.6
XLT5415I	150	2175	54	65	14.3	17.2	1450	1740	21.2	25.4	15.6	18.7

Dimensioni d'ingombro

Overall dimensions

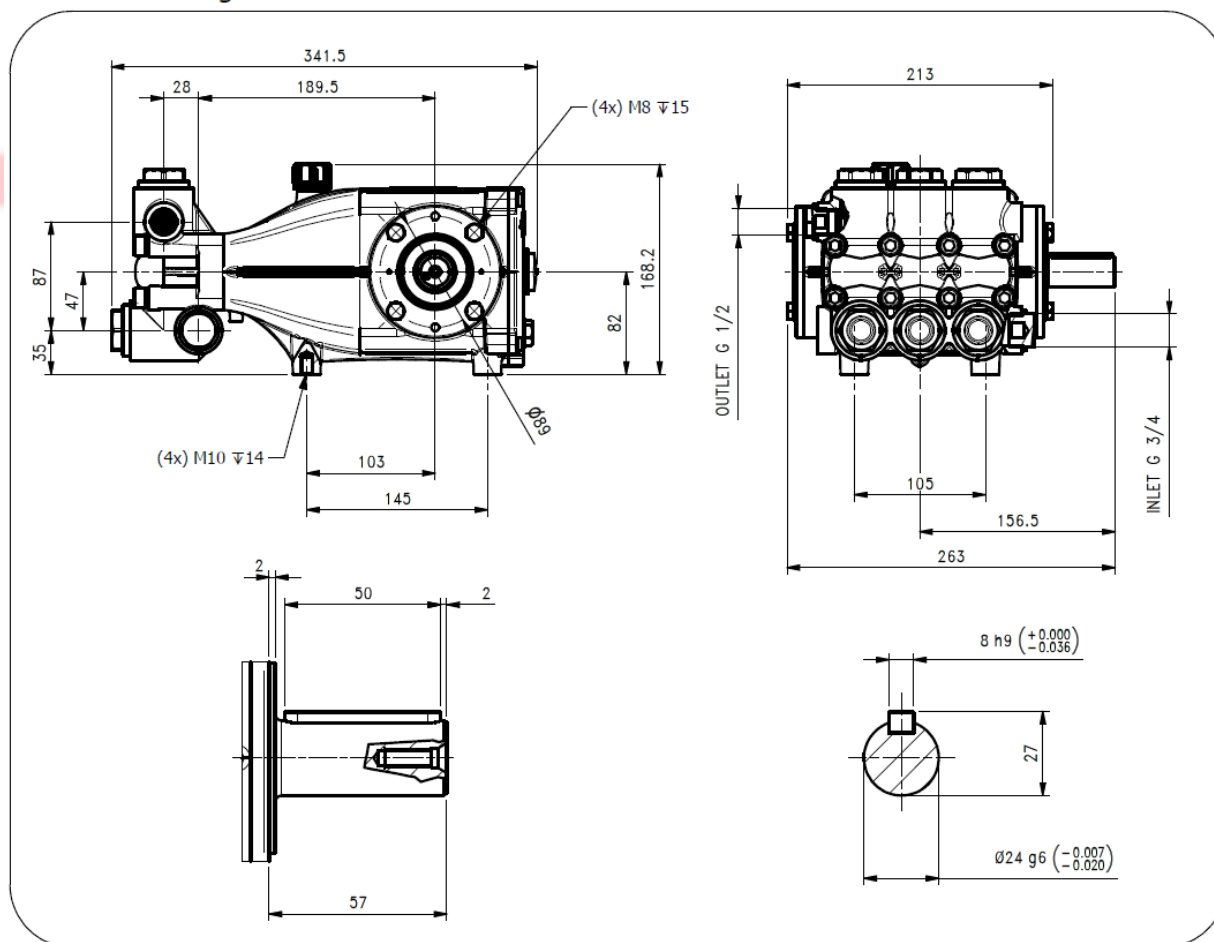

Lubrificazione: Olio SAE 10W40
 Capacità: 1.2 Litri
 Peso pompa: 17.8 kg

Lubrication: SAE 10W40 Oil
 Capacity: 1.2 Litres
 Weight: 17.8 kg

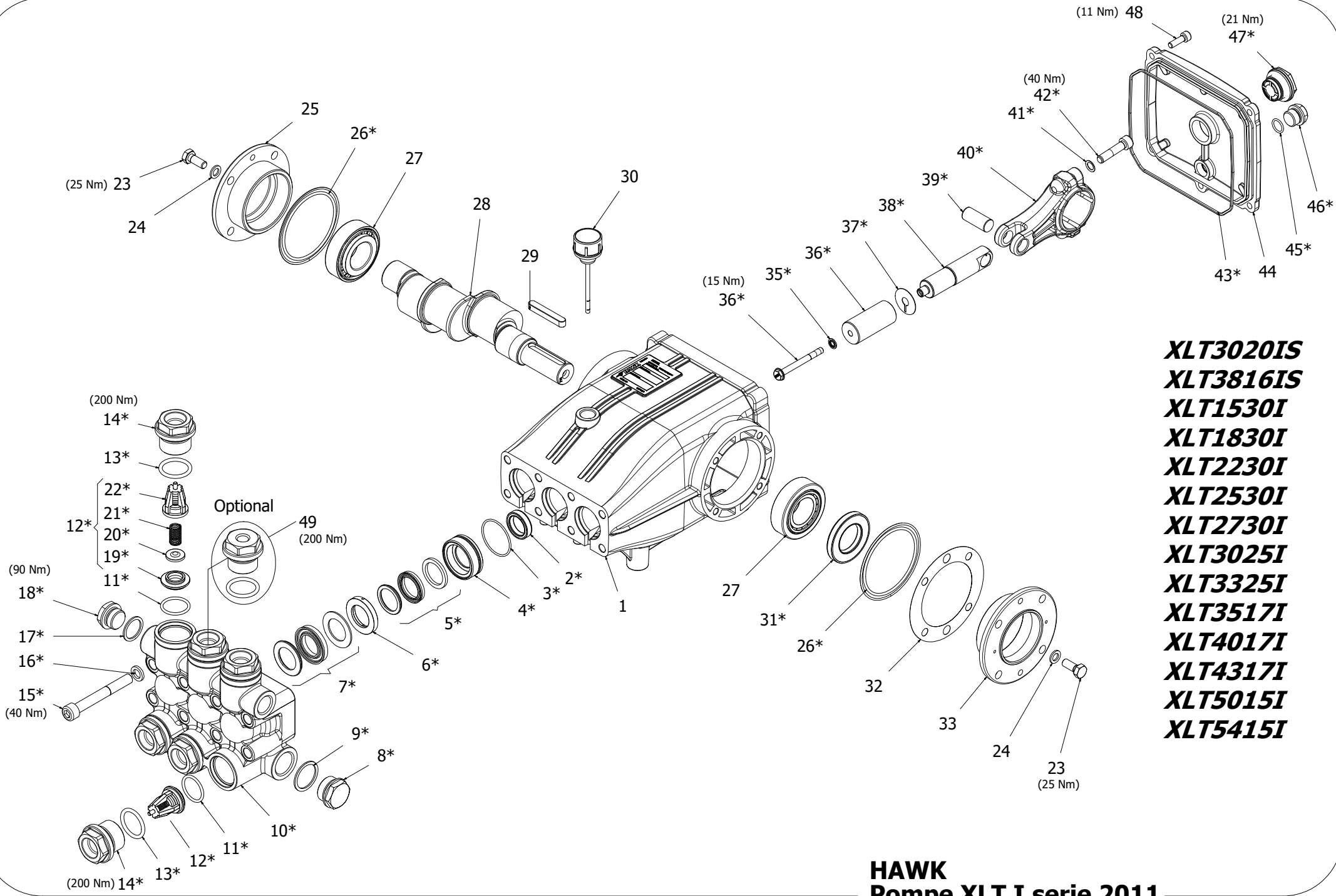

- XLT3020IS***
- XLT3816IS***
- XLT1530I***
- XLT1830I***
- XLT2230I***
- XLT2530I***
- XLT2730I***
- XLT3025I***
- XLT3325I***
- XLT3517I***
- XLT4017I***
- XLT4317I***
- XLT5015I***
- XLT5415I***

HAWK
Pompe XLT I serie 2011
XLT I pumps 2011 series

XLT I 2011 SERIES

ORDINARY MAINTENANCE KIT / KIT MANUTENZIONE ORDINARIA

KIT	Item Pos.	Part Number Codice	Description	Descrizione	Q.TY by Pump Q.TA per Pompa	XL T73020IS	XL T3816IS	XL T1530I	XL T1830I	XL T2230I	XL T2530I	XL T2730I	XL T3025I	XL T3325I	XL T3517I	XL T4017I	XL T4317I	XL T5015I	XL T5415I	
A	3- 5- 7	1.099-759.0	PLUNGER SEALS DIA. 20 mm	GUARNIZIONI PISTONE Ø20	1			•	•	•	•	•								
		1.099-769.0	PLUNGER SEALS DIA. 22 mm	GUARNIZIONI PISTONE Ø22									•	•						
		1.099-770.0	PLUNGER SEALS DIA. 25 mm	GUARNIZIONI PISTONE Ø25		•										•	•	•		
		1.099-771.0	PLUNGER SEALS DIA. 28 mm	GUARNIZIONI PISTONE Ø28		•														•
B	11- 12 (19 20- 21- 22) 13	1.905-686.0	COMPLETE VALVE	VALVOLA COMPLETA	1	•	•								•	•	•	•	•	
	11- 12 (19 20- 21- 22) 13	1.905-687.0	COMPLETE VALVE	VALVOLA COMPLETA				•	•	•	•	•	•	•						

EXTRAORDINARY MAINTENANCE KIT / KIT MANUTENZIONE STRAORDINARIA

KIT	Item Pos.	Part Number Codice	Description	Descrizione	Q.TY by Pump Q.TA per Pompa	XL T73020IS	XL T3816IS	XL T1530I	XL T1830I	XL T2230I	XL T2530I	XL T2730I	XL T3025I	XL T3325I	XL T3517I	XL T4017I	XL T4317I	XL T5015I	XL T5415I	
C	3- 4- 5- 6- 7	1.905-670.0	COMPLETE SEALS PACKING DIA. 20 mm	PACCO COMPLETO GUARNIZIONI PISTONE Ø20	1			•	•	•	•	•								
		1.905-852.0	COMPLETE SEALS PACKING DIA. 22 mm	PACCO COMPLETO GUARNIZIONI PISTONE Ø22									•	•						
		1.905-853.0	COMPLETE SEALS PACKING DIA. 25 mm	PACCO COMPLETO GUARNIZIONI PISTONE Ø25		•										•	•	•		
		1.905-854.0	COMPLETE SEALS PACKING DIA. 28 mm	PACCO COMPLETO GUARNIZIONI PISTONE Ø28		•														•
D	34- 35- 36 37	1.099-763.0	PLUNGER DIA. 20 mm	PISTONE Ø20	3			•	•	•	•	•								
		1.099-776.0	PLUNGER DIA. 22 mm	PISTONE Ø22									•	•						
		1.099-777.0	PLUNGER DIA. 25 mm	PISTONE Ø25		•										•	•	•		
		1.099-778.0	PLUNGER DIA. 28 mm	PISTONE Ø28		•														•
E	2	1.099-766.0	PLUNGER OIL SEALS	ANELLI TENUTA OLIO ASTA	1	•	•	•	•	•	•	•	•	•	•	•	•	•	•	

“Q.TY by Pump” => Necessary quantity to repair one pump
 “Q.TA’ per Pompa” => Quantità necessaria per riparare una pompa

EXTRAORDINARY MAINTENANCE KIT / KIT MANUTENZIONE STRAORDINARIA

KIT	Item Pos.	Part Number Codice	Description	Descrizione	Q.TY by Pump Q.TA per Pompa	XL T73020IS	XL T3816IS	XL T1530I	XL T1830I	XL T2230I	XL T2530I	XL T2730I	XL T3025I	XL T3325I	XL T3517I	XL T4017I	XL T4317I	XL T5015I	XL T5415I		
F	26- 31- 43 45- 46- 47	1.905-613.0	KIT CRANKCASE SEALS	KIT TENUTE CARTER	1	•	•	•	•	•	•	•	•	•	•	•	•	•	•		
G	3- 4- 5- 6- 7 8- 9- 10- 11 12 (19- 20 21- 22) 13 14- 15- 16 17- 18	1.099-781.0	COMPLETE MANIFOLD 20	TESTATA COMPLETA Ø20	1			•	•	•	•										
		1.099-782.0	COMPLETE MANIFOLD 22	TESTATA COMPLETA Ø22									•	•							
		1.099-783.0	COMPLETE MANIFOLD 25	TESTATA COMPLETA Ø25		•											•	•	•		
		1.099-784.0	COMPLETE MANIFOLD 28	TESTATA COMPLETA Ø28		•														•	•
H	38- 39- 40 41- 42	1.904-180.0	CONNECTING ROD PLUNGER ROD ASSY	PREMONTATO ASTA-BIELLA PISTONE	3	•	•	•	•	•	•	•	•	•	•	•	•	•	•		
I	13- 14	1.904-260.0	VALVE PLUG ASSY	PREMONTATO TAPPO VAM	6	•	•								•	•	•	•	•		
		1.904-262.0	VALVE PLUG ASSY	PREMONTATO TAPPO VAM			•	•	•	•	•	•	•	•							



“Q.TY by Pump” => Necessary quantity to repair one pump
“Q.TA’ per Pompa” => Quantità necessaria per riparare una pompa

OPTIONAL

Item Pos.	Part Number Codice	Description	Descrizione	Q.TY by Pump Q.TA per Pompa	XL T73020IS	XL T3816IS	XL T1530I	XL T1830I	XL T2230I	XL T2530I	XL T2730I	XL T3025I	XL T3325I	XL T3517I	XL T4017I	XL T4317I	XL T5015I	XL T5415I
49	9.853-428.0	THREADED BRASS PLUG G1/4	PREMONTATO TAPPO FORATO	1	•	•								•	•	•	•	•
	9.853-427.0	THREADED BRASS PLUG G1/4	PREMONTATO TAPPO FORATO	1			•	•	•	•	•	•	•					

TOOL KIT

Part Number Codice	Description	Descrizione	Q.TY by Pump Q.TA per Pompa	XL T73020IS	XL T3816IS	XL T1530I	XL T1830I	XL T2230I	XL T2530I	XL T2730I	XL T3025I	XL T3325I	XL T3517I	XL T4017I	XL T4317I	XL T5015I	XL T5415I	
1.099-665.0	TOOL-KIT	TOOL-KIT	1															
1.905-659.0	OIL SEAL EXTRACTOR TOOL-KIT	TOOL-KIT ESTR. PARAOLIO	1	•	•	•	•	•	•	•	•	•	•	•	•	•	•	•

IMPORTANT

IMPORTANTE

* Part available **ONLY** in kit
Disponibile **SOLO** in kit

(...) Parts pre-assembled
Parti pre-assemblate

PARTS LIST LISTA PARTI

Item Pos	Part Number Codice	Description	Descrizione	KIT	Q.TY Q.TA	XL T73020IS	XL T3816IS	XL T1530I	XL T1830I	XL T2230I	XL T2530I	XL T2730I	XL T3025I	XL T3325I	XL T3517I	XL T4017I	XL T4317I	XL T5015I	XL T5415I		
1	9.850-377.0	CRANKCASE	CARTER		1																
2*		PLUNGER OIL SEAL	ANELLO RADIALE	E	3	•	•	•	•	•	•	•	•	•	•	•	•	•	•		
3*		"O" RING Ø1.78X37.82	"O" RING Ø1.78X37.82	A-C-G	3																
4*		PRESSURE RING 20MM	PRESSORE "U" Ø20	C-G	3			•	•	•	•	•									
		PRESSURE RING 22MM	PRESSORE "U" Ø22											•	•						
		PRESSURE RING 25MM	PRESSORE "U" Ø25					•									•	•	•		
		PRESSURE RING 28MM	PRESSORE "U" Ø28						•											•	•
5*		LOW PRESSURE "U" SEAL, DIA.20MM	ANELLO TENUTA "U" Ø20	A-C-G	3			•	•	•	•	•									
		LOW PRESSURE "U" SEAL, DIA.22MM	ANELLO TENUTA "U" Ø22											•	•						
		LOW PRESSURE "U" SEAL, DIA.25MM	ANELLO TENUTA "U" Ø25					•									•	•	•		
		LOW PRESSURE "U" SEAL, DIA.28MM	ANELLO TENUTA "U" Ø28						•											•	•
6*		INTERMED. RING 20MM	DIFFUSORE INTER. Ø20	C-G	3			•	•	•	•	•									
		INTERMED. RING 22MM	DIFFUSORE INTER. Ø22											•	•						
		INTERMED. RING 25MM	DIFFUSORE INTER. Ø25					•									•	•	•		
		INTERMED. RING 28MM	DIFFUSORE INTER. Ø28						•											•	•
7*		HIGH PRESSURE "U" SEAL, DIA.20MM	ANELLO TENUTA "U" Ø20	A-C-G	3			•	•	•	•	•									
		HIGH PRESSURE "U" SEAL, DIA.22MM	ANELLO TENUTA "U" Ø22											•	•						
		HIGH PRESSURE "U" SEAL, DIA.25MM	ANELLO TENUTA "U" Ø25					•									•	•	•		
		HIGH PRESSURE "U" SEAL, DIA.28MM	ANELLO TENUTA "U" Ø28						•											•	•
8*		BRASS PLUG G 3/4	TAPPO G 3/4	G	1	•	•	•	•	•	•	•	•	•	•	•	•	•			
9*		COPPER WASHER G 3/4	GUARNIZIONE RAME G3/4	G	1																
10*		MANIFOLD HOUSING 28/25	TESTATA Ø28/25	G	1	•	•								•	•	•	•			
		MANIFOLD HOUSING 22/20	TESTATA Ø22/20						•	•	•	•	•	•							
11*		"O" RING Ø2.62X25.07	"O" RING Ø2.62X25.07	B-G	6	•	•								•	•	•	•			
		"O" RING Ø2.62X21.89	"O" RING Ø2.62X21.89						•	•	•	•	•	•							
12*		VALVE ASSEMBLY	VALVOLA PREMONTATA	B-G	6	•	•								•	•	•	•			
		VALVE ASSEMBLY	VALVOLA PREMONTATA						•	•	•	•	•	•							
13*		"O" RING Ø2.62X26.58	"O" RING Ø2.62X26.58	B-G-I	6	•	•								•	•	•	•			
		"O" RING Ø2.62X25.80	"O" RING Ø2.62X25.80						•	•	•	•	•	•							
14*		VALVE PLUG	TAPPO VALVOLA	G-I	6	•	•								•	•	•	•			
		VALVE PLUG	TAPPO VALVOLA						•	•	•	•	•	•							
15*		MANIFOLD STUD BOLT	VITE M10X80 GEOMET	G	8																
16*		LOCK-WASHER	ROSETTA ELASTICA	G	8	•	•	•	•	•	•	•	•	•	•	•	•	•			
17*		COPPER WASHER G1/2	GUARNIZIONE RAME G1/2	G	1																
18*		BRASS PLUG G1/2	TAPPO G1/2	G	1																

Item Pos	Part Number Codice	Description	Descrizione	KIT	Q.TY Q.TÀ	XL T73020IS	XL T3816IS	XL T1530I	XL T1830I	XL T2230I	XL T2530I	XL T2730I	XL T3025I	XL T3325I	XL T3517I	XL T4017I	XL T4317I	XL T5015I	XL T5415I	
19*		VALVE SEAT	SEDE VALVOLA	B-G	6	•	•								•	•	•	•	•	
		VALVE SEAT	SEDE VALVOLA	B-G	6			•	•	•	•	•	•							
20*		VALVE PLATE	PIATTELLO VALVOLA	B-G	6															
21*		VALVE SPRING	MOLLA VALVOLA	B-G	6															
22*		VALVE CAGE	GABBIA VALVOLA	B-G	6															
23	9.851-503.0	HEXAGONAL SCREW	VITE M8X20		8															
24	9.851-114.0	WASHER DIA. 8.5	ROSETTA Ø8.5		8	•	•	•	•	•	•	•	•	•	•	•	•	•	•	
25	9.850-620.0	CLOSED BEARING HOUSING	FLANGIA CHIUSA		1															
26*		"O" RING Ø2.62X71.12	"O" RING Ø2.62X71.12	F	2															
27	9.850-347.0	ROLLER BEARING	CUSCINETTO A RULLI		2															
28	9.850-194.0	CRANKSHAFT DIA. 24 MM	ALBERO Ø24		1				•											
	9.850-192.0	" " " "	" "							•						•				
	9.850-193.0	" " " "	" "								•						•			•
	9.850-191.0	" " " "	" "				•	•				•				•			•	•
	9.850-222.0	" " " "	" "						•											
29	9.850-447.0	CRANKSHAFT KET	CHIAVETTA		1															
30	9.851-287.0	OIL DIP STICK	TAPPO LIVELLO OLIO		1															
31*		CRANKSHAFT SEAL	ANELLO RADIALE	F	1															
32	9.850-546.0	SHIM	DISTANZIALE		1	•	•	•	•	•	•	•	•	•	•	•	•	•	•	
33	9.850-610.0	BEARING HOUSING	FLANGIA APERTA		1															
34*		PLUNGER BOLT	VITE PISTONE	D	3															
35*		COPPER SPACER	ROSETTA RAME	D	3															
36*		PLUNGER DIA. 20 MM	PISTONE Ø20	D	3			•	•	•	•	•								
		PLUNGER DIA. 22 MM	PISTONE Ø22	D										•	•					
		PLUNGER DIA. 25 MM	PISTONE Ø25	D			•									•	•	•		
		PLUNGER DIA. 28 MM	PISTONE Ø28	D				•												•
37*		COPPER SPACER	ROSETTA RAME	D	3															
38*		PLUNGER ROD	ASTA PISTONE	H	3															
39*		CONNECTING ROD PIN	SPINOTTO	H	3															
40*		CONNECTING ROD	BIELLA	H	3															
41*		SPRING WASHER	ROSETTA ELASTICA Ø8	H	6															
42*		CONNECTING ROD SCREW	VITE BIELLA	H	6															
43*		"O" RING Ø2.62X152.07	"O" RING Ø2.62X152.07	F	1	•	•	•	•	•	•	•	•	•	•	•	•	•	•	
44	9.850-389.0	CRANKCASE COVER	COPERCHIO		1															
45*		"O" RING Ø1.78X14.00	"O" RING Ø1.78X14.00	F	1															
46*		BRASS PLUG G 3/8	TAPPO OTTONE G 3/8	F	1															
47*		SIGHT GLASS, G 3/4	SPIA LIVELLO OLIO	F	1															
48	9.851-474.0	COVER SCREW	VITE COPERCHIO		5															